

# Islands

Durbanis  
2019

# durbanis

Sizes in cm

Material: Colored in mass reinforced concrete, acid etched and waterproofed.

Weight: Island S1 1.800kg / Island L1 2.500kg. / Island L2 3.000kg.

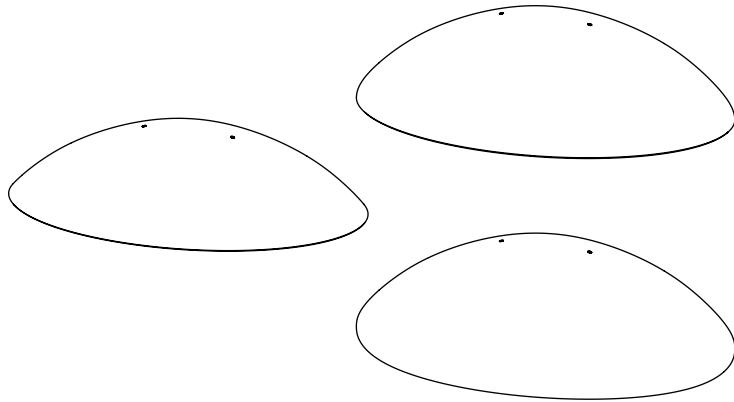

## Placement system

Handling with long polyester slings.

Free-standing element. Supported on the ground.

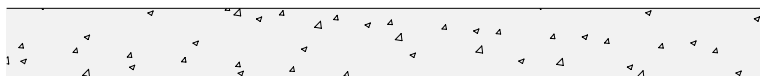
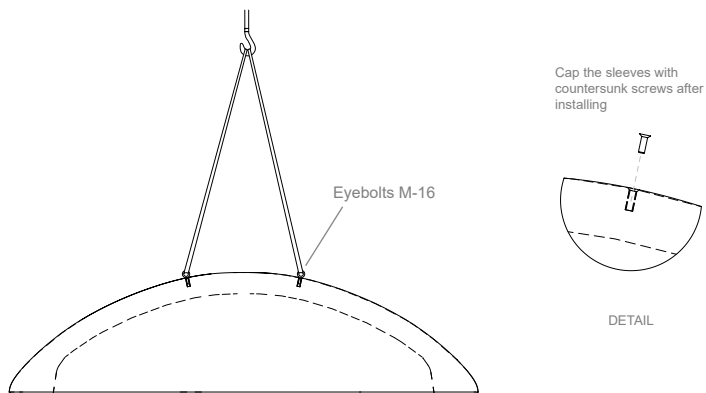

## ISLAND S1

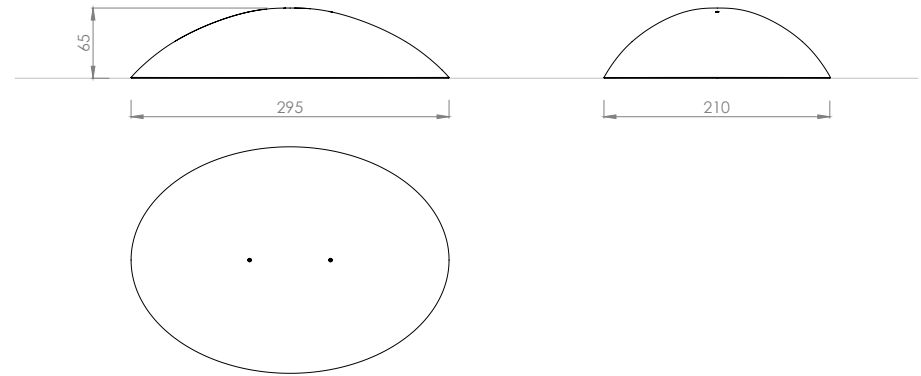

## ISLAND L1

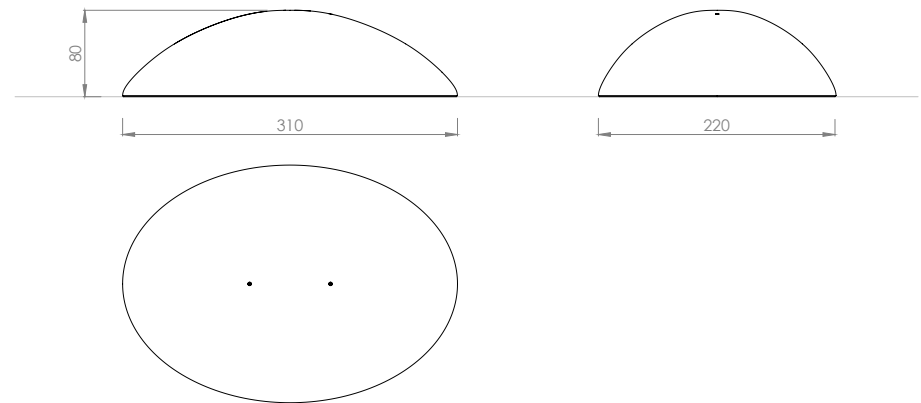

## ISLAND L2

